



Product Guide 2015

- Touch Screen Displays
- POS Terminals
- POS Computers
- POS Printers
- POS Accessories
- Cash Drawers
- Wall and Tablet Mounts
- Kiosks/Panel Mounts



Point of Sale.....Retail.....Industrial.....Custom OEM Manufacturing

USA Corporate Office

UnyPOS Manufacturing Inc.

4100 E. Baldwin Rd.
Holly Michigan 48442
Telephone: 877-219-3988 (Toll Free)
Telephone: 810-953-3901
Fax: 810-953-3913

Canadian Office

UnyPOS MFG. Inc.

10 Loring Dr, Bldg A, Unit 11
Bolton, Ontario L7E 1Y1
Telephone: 877-219-3988 (Toll Free)
Telephone: 905-951-0322

Www.UnyPOS.Com

Sales@UnyPOS.Com

USA....Canada....Latin America

Profile

UnyPOS Manufacturing is a Developer of Point of Sale Products, Industrial-Commercial Touch Screen Displays, Cash Drawers and Custom OEM Solutions. With over 22 years of manufacturing experience, we began by supplying rugged touch screen displays to the hospitality industry. Since that time we have grown significantly and now produce our own range of products such as Cash Drawers, Touch Screen Displays, POS Terminals and Accessories. Our range of Cash Drawers and Touch Screens are designed and Integrated on our premises in Michigan, USA and also with sales and distribution offices located in Canada and Latin America. We offer product stability, reliability and a level of after-sales support that is second to none. We are also able to offer an Advance Swap Warranty Service that addresses the most challenging of applications, regardless of the quantity required. Although still supplying into Point of Sale Applications, our customer base has widened significantly to include:

- Food Process, Security and Retail
- Marine and Offshore, Military
- Kiosk/Point of Information Displays
- Hospitality and Leisure

Our Company Values:

We are an engineering services and manufacturing oriented company that values integrity, flexibility, customer service, quality, commitment, teamwork and profitability to our partners.

Michigan Corporate Office (USA)



Bolton Ontario Office (Canada)



Android 4.1 OS 15" LCD Touch Screen AIO

UnyPOS first Android 15" Touch All in One Terminal developed based on the TAP-15-2RT-E Touch Screen Monitor. Android 4.1 OS with a 1.6GHz Dual Core Processor enables the AIO to handle various heavy loads faster and more smoothly. It supports 1GB Ram and up to 32GB flash memory with SD card slot. Integrated with Wi-Fi 802.11 b/g/n and 10/100Mb Ethernet RJ45 the computer offers convenient access for users to configure their networks.



Specifications:

TAP-15Droid

- **Size:** 15" 4:3 TFT LCD Panel
- **Touch:** 5-Wire Resistive
- **Resolution:** 1024 x 768 @ 75 Hz
- **Brightness:** 250 nits
- **Contrast:** 600:1
- **HDD:** Standard SSD 64GB
- **CPU:** Rockchip RK3066
- **Memory:** 1GB
- **Flash:** 8GB
- **SD Card Slot:** Yes (Max 32 Gb)
- **Wireless:** Wifi 802.11 b/g/n
- **Lan :** 10/100
- **Ports :** 5x USB, 1x DC Jack, 1x Headphone, 1x RJ45, 1x Mic In
- **Speakers:** 2 W x 2 Channels
- **OS:** Android 4.1
- **Input Voltage:** +12VDC
- **Power Supply:** External Adaptor 100-240 VAC
- **Dimensions Shipping:** 354mm x 313mm 206.5mm
- **Weight:** Monitor 4.1Kg, Shipping 7.1Kg
- **Certifications:** FCC, CE, CCC
- **Color:** Black

Options:

- Optional MSR USB Reader and Bracket
- Optional SD Card up to 32Gb Max
- Optional Wall Mount Bracket

Main Features:

- Exclusive Body Shape
- Powerful Dual-Core Arm Processor
- WiFi & RJ45 Network Connections
- 4 USB Ports, SD Memory Slot
- Android 4.1 OS
- High Quality Touch Screen



Rear View of Ports

True Flat 15" Zero Bezel AIO

The Innovative UnyPOS 15" ZERO BEZEL All-in-One-POS Terminal designed with a TRUE FLAT panel comes standard with Multi I/O expansion capabilities that enables you to interface your system with many external devices. Equipped with Powerful Intel processor that is embedded on to a feature-rich motherboard.



Specifications:

UNY-UZ15A (Fanless)

- **Size:** 15" 4:3 TFT LCD Panel
- **Touch Technology:** 5 Wire Resistive, True Flat Zero Bezel
- **Resolution:** 1024 x 768 @ 75 Hz
- **Brightness:** 250 nits
- **Contrast:** 1000:1
- **HDD:** 320gb 2.5" Sata (**Easy Swap**)
- **CPU:** Intel Atom D2550 (1M Cache, 1.86GHz)
- **Memory:** DDR3-800/1066 4GB, 1xSO-DIMM Memory Slot
- **Socket:** 775
- **FSB:** 800MHz
- **Graphics:** 640MHz
- **Audio:** 1 Audio Jack,; Line Out
- **Built-in Speakers:** No
- **Lan Card:** 10/100/1000M
- **I/O Ports:** 5x USB 2.0, 4x RS232, 1x PS2, 1x VGA, 1x RJ45, 1 x line out, 1x Mic, 1x 12V DC out for 2nd display
- **OS:** Optional
- **Power:** AC 100-240 VAC, 50/60 Hz DC: 12 VDC, 7.5A, 30W
- **Temperature Operating:** 0 C to 40 C (32 F to 104 F)
- **Temperature Storage:** -20 C to 60 C (-4 F to 140 F)
- **Humidity Operating:** 20% to 80%
- **Humidity Storage:** 10% to 90%
- **Dimensions Shipping (WxHxD):** 260mm x430mm x470mm
- **Weight:** 12 lbs (5.44Kg)
- **Color:** Black
- **Certification:** CE, UL, FCC
- **Warranty:** Two Year Parts and Labor

↓ Fanless Model Ports



↕ Easy Swap Hard Drive



↑ I3 Model Ports

Main Features

- **Zero Bezel**
- **Plenty of I/O Ports**
- **Economical**
- **Cable Management**
- **Compact Enclosure**
- **Easy Swap HDD**

UNY-UZ15I (I3) Model Upgrade

- **CPU:** Intel Core I3-3110M Motherboard @ 2.4Ghz
- **I/O Ports:** 3x USB 2.0, 2x USB 3.0, 3x RS232, 1x PS2, 1x VGA, 1x RJ11, 1x RJ45, 1 x line out, 1x Mic, 1x 12V DC out for 2nd display

Options:

- **3-Track USB Card Stripe Reader** Part# UNY-UZ15-MSR
- **2x20 Rear VFD Customer Display** Part#UNY-VFD-220U
- **10.4" Rear LCD Display** Part# UR-104-VGA-RD
- **Wall Mount Bracket** Part# UR-RTW03

Modular POS Terminal Fanless (H-Series)

The Modular (H) Horizontal Housing is made of high quality powder coated steel for ultimate sturdiness and durability to stand up to the harshest environments. Combined with a 15" Touch Screen, MiniBOX Computer and our ModPOS housing, you can create a low cost modular powerful A-I-O terminal.



Pictures Shown with Optional MSR and Rear Display LCD

ModPOS-15A (Fanless)

- **TOUCH:** 5 Wire Resistive Anti-Glare
- **MOTHERBOARD:** Intel Motherboard D2550
- **CPU:** Intel Atom Dual Core 1.87Ghz CPU Fanless
- **MEMORY:** 4 GB DDR3-1333 Max 4GB
- **HARD DRIVE:** 500GB SATA 5400 rpm
- **VIDEO GRAPHICS:** Intel GMA x 4500
- **BRIGHTNESS:** 250 Nits
- **PORTS:** 4x USB 2.0, 2x RS232, 1x SVGA, 1x S-Video, 1x Lan, 1x LPT1, 1x Audio
- **LAN:** 1x RJ45 10/100 /1000
- **CASING:** Modular Rugged Metal Housing
- **WEIGHT:** 24lbs/10.9kg Includes Packaging
- **POWER:** External 220W Power Supply Adaptor 6a
- **LCD DISPLAY:** TAP High Bright 15" 1024x768, 16.7M Colors
- **DIMENSIONS (LxWxH):** 380mm x 270mm x 330mm (Includes Stand)
- **CERTIFICATIONS:** FCC Class A, CE, RoHs
- **OPERATING SYSTEMS:** Optional

- **WARRANTY:** 3 Year Parts and Labor



Easy Access to MiniBOX PC

Options

- **Optional MSR Bracket**
- **Optional 3 Track USB MSR**
- **Optional Rear 8.4" USB LCD**
- **Optional VFD USB Display**
- **Upgrade to 17"**
- **Upgrade to 19"**

Modular POS Terminal I3 (H-Series)

Specifications:

ModPOS-ST15-I3 (I3)

- **TOUCH:** 5 Wire Resistive Anti-Glare
- **MOTHERBOARD:** Gigabyte H81N
- **CPU:** Intel Core I3 4130 2.9Ghz
- **MEMORY:** 4 GB DDR3-1333 (Max 8GB only Win 7 64 bit)
- **HARD DRIVE:** 500GB SATA 5400 rpm
- **VIDEO GRAPHICS:** Intel HD Graphics VGA/DVI/HDMI
- **Audio:** Realtek ALC887 High Definition
- **BRIGHTNESS:** 250 Nits
- **PORTS:** 4x USB 2.0, 2x USB 3.0, 1x RS232, 1x VGA, 1x HDMI, 1x DVI, Audio Ports
- **LAN:** 1x RJ45 10/100/1000
- **CASING:** Modular Rugged Metal Housing Powder Coated
- **WEIGHT:** 24lbs/10.9kg Includes Packaging
- **POWER:** External 220W Power Supply Adaptor 10a
- **LCD DISPLAY:** TAP High Bright 15" 1024x768, 16.7M Colors
- **DIMENSIONS (LxWxH):** 380mm x 270mm x 330mm (Includes Stand)
- **CERTIFICATIONS:** FCC Class A, CE, RoHs
- **OPERATING SYSTEMS:** Optional

Options:

- **WARRANTY:** 3 Year Parts and Labor
- **Optional MSR Bracket**
- **Optional 3 Track USB MSR**
- **Optional Rear 8.4" USB LCD**
- **Optional VFD USB Display**
- **Upgrade to 17"**
- **Upgrade to 19"**

Main Features:

- **Separate LCD, PC and ModPOS Housing**
- **15" High Bright TAP Touch Screen Display**
- **Easy to Service and Swap Components**
- **Available in many configurations**
- **Detachable Rear Cover for Access to MiniBox**
- **Powder Coated Metal ModPOS Housing**
- **Heavy Duty, Industrial**
- **Reliable**
- **True Intel Processor and Motherboard**



Rear View of Detachable MiniBox PC

Includes USB Port on Front Panel for Quick Access



Modular POS Terminal Fanless & I3 (V-Series)



Specifications:

ModPOS-ST15-I3 (I3)

- **TOUCH:** 5 Wire Resistive Anti-Glare
- **MOTHERBOARD:** Gigabyte H81N
- **CPU:** Intel Core I3 4130 Quad Core 2.9Ghz
- **MEMORY:** 4 GB DDR3-1333 (Max 8GB only Win 7 64 bit)
- **HARD DRIVE:** 500GB SATA 5400 rpm
- **VIDEO GRAPHICS:** Intel HD Graphics VGA/DVI/HDM
- **Audio:** Realtek ALC887 High Definition
- **BRIGHTNESS:** 250 Nits
- **PORTS:** 4x USB 2.0, 2x USB 3.0, 1x RS232, 1x VGA, 1x HDMI, 1x DVI Audio Ports
- **LAN:** 1x RJ45 10/100/1000
- **CASING:** **Modular** Rugged Metal Housing Powder Coated
- **WEIGHT:** 30 lbs/13.6 kg Includes Packaging
- **POWER:** External 220W Power Supply Adaptor 10a
- **LCD DISPLAY:** TAP High Bright 15" 1024x768, 16.7M Colors
- **DIMENSIONS (LxWxH):** 380mm x 270mm x 330mm (Includes Stand)
- **CERTIFICATIONS:** FCC Class A, CE, RoHs
- **OPERATING SYSTEMS:** Optional



Includes USB Port on Front Panel for Quick Access

ModPOS-15V (Fanless)

- **TOUCH:** 5 Wire Resistive Anti-Glare
- **MOTHERBOARD:** Intel Motherboard D2550
- **CPU:** Intel Atom Dual Core 1.87Ghz CPU Fanless
- **MEMORY:** 4 GB DDR3-1333 Max 4GB
- **HARD DRIVE:** 500GB SATA 5400 rpm
- **VIDEO GRAPHICS:** Intel GMA x 4500
- **BRIGHTNESS:** 250 Nits
- **PORTS:** 4x USB 2.0, 2x RS232, 1x SVGA, 1x S-Video, 1x LPT1, 1x Audio
- **LAN:** 1x RJ45 10/100/1000
- **CASING:** **Modular** Rugged Metal Housing
- **WEIGHT:** 30lbs/13.6kg Includes Packaging
- **POWER:** External 220W Power Supply Adaptor 6a
- **LCD DISPLAY:** TAP High Bright 15" 1024x768, 16.7M Colors
- **DIMENSIONS (LxWxH):** 380mm x 270mm x 330mm (Includes Stand)
- **CERTIFICATIONS:** FCC Class A, CE, RoHs
- **OPERATING SYSTEMS:** Optional

Main Features:

- Separate LCD, PC and ModPOS Housing
- 15" High Bright TAP Touch Screen Display
- Easy to Service and Swap Components
- Available in many configurations
- Detachable Rear Cover for Access to MiniBox
- Powder Coated Metal ModPOS Housing
- Heavy Duty, Industrial
- Reliable
- True Intel Processor and Motherboard

Options:

- Optional MSR Bracket
- Optional 3 Track USB MSR
- Optional Rear 8.4" USB LCD
- Optional VFD USB Display
- Upgrade to 17"
- Upgrade to 19"
- Optional ModPOS Lite Kit
Part# UNY-P-A1.6F



ModPOS-Lite Terminal

TAP Touch Screen Displays

Experience the latest in adaptive LCD design with the TAP Touch Screen Displays. An attractive, slim, space saving design the screen incorporates a bright, high contrast ratio with wide viewing angles to improve image quality at various viewing angles. Comes standard with Dual Touch Interface USB/Serial and Ergonomic Cable Management Stand.

TAP-15-2RT-E 15"

- **Touch:** 5 Wire Resistive Anti-Glare
- **Interface:** USB A-B, RS232
- **Display:** VGA 640x480, 800x600, XGA 1024x768(60/70/75hz)
- **Resolution:** 1024(H) x 768(V)
- **Brightness:** 250 Nits
- **Contrast:** 500:1
- **Viewing Angle:** 120 degree (H), 100 degree (V)
- **Response Time:** 8ms
- **Signal Input:** Video/Analog Signal, Signal Sync TTL
- **Signal Output:** VGA D-Sub
- **OSD:** Control Brightness, contrast, auto, color, user color etc
- **Power Supply:** 12V DC 3.3A
- **Power:** <=30W (Max)
- **Attachment Signal Line Power Adaptor**
- **Dimension (WxHxD)** 343mm x363mm x185mm (Includes Stand)
- **Color:** Black
- **Weight:** 15.8 lbs



Rear View

Side View

TAP-17-2RT-E 17"

- **Touch:** 5 Wire Resistive Anti-Glare, Optional SAW
- **Interface:** USB A-B, RS232
- **Display:** VGA 640x480, 800x600, XGA 1024x768(60/70/75hz)
- **Resolution:** 1280(H) x 1024(V)
- **Brightness:** 250 Nits
- **Contrast:** 1000:1
- **Viewing Angle:** -75/+75 (H) , -60/+60 degree (V)
- **Response Time:** 5ms
- **Signal Input:** Video/Analog Signal, Signal Sync TTL
- **Signal Output:** VGA D-Sub
- **OSD:** Control Brightness, contrast, auto, color, user color etc
- **Power Supply:** 12V DC 1.5A
- **Power:** <=30W (Max)
- **Attachment Signal Line Power Adaptor**
- **Dimension (LxWxH)** 343mm x363mm x185mm (Includes Stand)
- **Color:** Black
- **Weight:** 20.45 lbs

Optional Color Housing and Custom OEM Branding



Options

- Optional 19" Touch Screen Part# TAP-19-2RT-E
- Optional 22" Touch Screen Part# TAP-22-2RT-E
- Optional MSR USB Reader Programmable Part# US-MSR-3TRK-U
- Optional MSR Mounting Bracket UNY-MSRBR-U41



MSR Mounting Bracket



MSR USB Reader

Cash Drawer Family of Excellence

The UnyPOS Family of Cash Drawers carries a classic construction that employs precise Plastic or Steel Ball Bearings which the rails open smoothly and move actively. Designed with SPCC Powder Coated Rolling Steel and Electroplating Rust Resistant Zinc base that provides all our drawers with Excellence.



Quick Features:

- Micro Switch
- Nylon or Ball Bearing Rollers
- SPCC Powder Coated Rolling Steel, Rust Resistant Material
- 3-Position Electronic Key Lock
- Cable Included
- Competitive Pricing directly from the Manufacturer

Applications:

- Retail/Hospitality/Industrial/Medical/Education/Home Office

Models

- UZ-HS330A Mini Foot Print
- UZ-HS410AE Deluxe
- UZ-HS410A Ultimate
- UZ-HS410AC Heavy Duty with Locking Lid
- UZ-HS410-MAN Manual
- UZ-HS460 Retail Heavy Duty
- UZ-HS400D1 Ball Bearing Rail and Locking Lid

Options

- UZ-USBTrigger-W8 USB to RS232 Trigger Win 8 Compatible
- UZ-USBTrigger-RS RS232 convertor to USB Trigger
- UZ-USBTrigger USB to RS232 Trigger

The UnyPOS Mini UZ-HS330A cash drawer is designed for minimal amount of counter space but carries the same functionality and mechanisms as the larger foot print UnyPOS Drawers.

UZ-HS330A Mini Foot Print

- Coin Holder: 8 Coin Adjustable
- Bill Holder: 4 bill slots with Metal Bill Clip
- Media Slot: Two
- Micro Switch: Yes
- Interface: RJ11
- Cable Management: Yes
- Dimensions (WxLxH): 330mm x 330mm 90mm (13x13x3.5")
- Rail: Nylon Bearings
- Weight: 4.4 Kgs
- Color: Black
- Material Shell: SPCC Powder Coated Rolling Steel
- Material Plate: SECC-N5 Electroplating Rust Resistant Zinc base
- Keys: Two
- Key Lock: 3-Position Electronic Key Lock
- Cable: Included (Compatible with Epson, Star, Bixolon, Citizen)



Cash Drawer

The Deluxe UZ-HS410AE cash drawer carries a classic construction that employs precise plastic bearings which the rails open smoothly and move actively. A 3-position key lock ensures the cash security.

UZ-HS410A E **Deluxe**



- **Coin Holder:** 8 Coin Adjustable
- **Bill Holder:** 4 or 5 bill slots with Metal Bill Clip
- **Media Slot:** Two
- **Micro Switch:** Yes
- **Solenoid:** 24V
- **Interface:** RJ11
- **Dimensions (WxLxH):** 410mm x 430mm 100mm
- **Rail:** Nylon Bearings
- **Weight:** 7.25 Kgs
- **Color:** Black
- **Material Shell:** SPCC Powder Coated Rolling Steel
- **Material Plate:** SECC-N5 Electroplating Rust Resistant Zinc base
- **Keys:** Two
- **Key Lock:** 3-Position Electronic Key Lock
- **Cable:** Included (Compatible with Epson, Star, Bixolon, Citizen)

Models

- **4b8c Model:** UZ-HS410AE-4B8C
- **5b8c Model:** UZ-HS410AE-5B8C

The UnyPOS Ultimate UZ-HS410A cash drawer carries a classic construction that employs precise plastic bearings which the rails open smoothly and move actively.

UZ-HS410A **Ultimate**

- **Coin Holder:** 8 Coin Adjustable
- **Bill Holder:** 4 or 5 bill slots with Metal Bill Clip
- **Media Slot:** Two
- **Micro Switch:** Yes
- **Solenoid:** 24V
- **Interface:** RJ11
- **Dimensions (WxLxH):** 410mm x 430mm 100mm
- **Rail:** Nylon Bearings
- **Weight:** 7.25 Kgs
- **Color:** Black
- **Material Shell:** SPCC Powder Coated Rolling Steel
- **Material Plate:** SECC-N5 Electroplating Rust Resistant Zinc base
- **Keys:** Two
- **Key Lock:** 3-Position Electronic Key Lock
- **Cable:** Included (Compatible with Epson, Star, Bixolon, Citizen)

Models

- **4b8c Model:** UZ-HS410A-4B8C
- **5b8c Model:** UZ-HS410A-5B8C



Cash Drawer

The **UnyPOS Heavy Duty UZ-HS410C** cash drawer carries a classic construction that employs precise plastic bearings which the rails open smoothly and move actively and comes standard with a **Locking Lid**.



**Removable Insert and Coin Tray
Locking Lid included**



UZ-HS410C

Heavy Duty

- **Coin Holder:** 8 Coin Adjustable
- **Bill Holder:** 4 or 5 bill slots with Metal Bill Clip
- **Locking Lid:** Yes (Key Included)
- **Media Slot:** One
- **Micro Switch:** Yes
- **Solenoid:** 24V
- **Interface:** RJ11
- **Dimensions (WxLxH):** 410mm x 430mm 100mm
- **Rail:** Nylon Bearings
- **Weight:** 7.95 Kgs
- **Color:** Black
- **Material Shell:** SPCC Powder Coated Rolling Steel
- **Material Plate:** SECC-N5 Electroplating Rust Resistant Zinc base
- **Keys:** Two
- **Key Lock:** 3-Position Electronic Key Lock
- **Cable:** Included (Compatible with Epson, Star, Bixolon, Citizen)

Models

- **4b8c Model:** UZ-HS410C-4B8C
- **5b8c Model:** UZ-HS410C-5B8C

The **UnyPOS Ultimate UZ-HS410A-MAN** manual cash drawer carries a classic construction that employs precise plastic bearings which the rails open smoothly and move actively.

UZ-HS410A-Man

Manual

- **Coin Holder:** 8 Coin Adjustable
- **Bill Holder:** 4 or 5 bill slots with Metal Bill Clip
- **Media Slot:** Two
- **Micro Switch:** No
- **Interface:** Manual
- **Dimensions (WxLxH):** 410mm x 430mm 100mm
- **Rail:** Nylon Bearings
- **Weight:** 7.25 Kgs
- **Color:** Black
- **Material Shell:** SPCC Powder Coated Rolling Steel
- **Material Plate:** SECC-N5 Electroplating Rust Resistant Zinc base
- **Keys:** Two
- **Key Lock:** 3-Position Key Lock

Models

- **4b8c Model:** UZ-HS410A-Man-4B8C
- **5b8c Model:** UZ-HS410A-Man-5B8C



Cash Drawer

The UnyPOS Retail Heavy Duty Ultimate UZ-HS460 cash drawer carries a classic construction that employs precise plastic bearings which the rails open smoothly and move actively.



UZ-HS460

Retail

- **Coin Holder:** 8 Coin Adjustable
- **Bill Holder:** 4 or 5 bill slots with Metal Bill Clip
- **Media Slot:** Two
- **Micro Switch:** Yes
- **Solenoid:** 24V
- **Interface:** RJ11
- **Cable Management:** Yes
- **Dimensions (WxLxH):** 460mm x 465mm 100mm
- **Rail:** Nylon Bearings
- **Weight:** 9.5 Kgs
- **Color:** Black
- **Material Shell:** SPCC Powder Coated Rolling Steel
- **Material Plate:** SECC-N5 Electroplating Rust Resistant Zinc base
- **Keys:** Two
- **Key Lock:** 3-Position Electronic Key Lock
- **Cable:** Included (Compatible with Epson, Star, Bixolon, Citizen)

Models

- **4b8c Model:** UZ-HS460-4B8C
- **5b8c Model:** UZ-HS460-5B8C

The UnyPOS Premium UZ-HS400D1 cash drawer designed with Ball Bearing Technology for smooth glide when rails open and patented insert with locking lid and handle with briefcase look for security.

UZ-HS400D1

Premium

- **Coin Holder:** 8 Coin Adjustable
- **Bill Holder:** 5 bill slots with Metal Bill Clip
- **Media Slot:** One
- **Locking Lid:** Yes
- **Micro Switch:** Yes
- **Solenoid:** 24V
- **Interface:** RJ11
- **Cable Management:** Yes
- **Dimensions (WxLxH):** 405mm x 430mm 90mm
- **Rail:** Steel Ball Bearing
- **Weight:** 8.5 Kgs
- **Color:** Black
- **Material Shell:** SPCC Powder Coated Rolling Steel
- **Material Plate:** SECC-N5 Electroplating Rust Resistant Zinc base
- **Keys:** Two
- **Key Lock:** 3-Position Electronic Key Lock
- **Cable:** Included (Compatible with Epson, Star, Bixolon, Citizen)



Insert and Locking Lid Standard



← **Ball Bearing Technology**

MiniBox PC

The UnyPOS MiniBOX PC is Specially Designed for Hospitality and Industrial Environments that with it's Unique Compact Design and State of the Art Technology...



↑ Fanless Rear View of Ports

Specifications:

UP-7765B-D2550 (Fanless)

- **MOTHERBOARD:** Intel Motherboard D2550
- **CPU:** Intel Atom Dual Core 1.87Ghz CPU Fanless
- **MEMORY:** 4 GB DDR3-1333 Max 4GB
- **HARD DRIVE:** 500GB SATA 5400 rpm
- **VIDEO GRAPHICS:** Intel GMA x 4500
- **PORTS:** 4x USB 2.0, 2x RS232, 1x SVGA, 1x S-Video, 1x Lan, 1x LPT1, 1x Audio
- **LAN:** 1x RJ45 10/100/1000
- **CASING:** Modular Rugged Metal Housing
- **WEIGHT:** 3.3lbs/1.5kg Includes Packaging
- **POWER:** External 220W Power Supply Adaptor 6a
- **DIMENSIONS (LxWxH):** 58.5mm x 259.5mm x 186mm
- **CERTIFICATIONS:** FCC Class A, CE, RoHs
- **OPERATING SYSTEMS:** Optional

Power the Future with the Powerful I3 Quad Core MiniBOX PC



↑ I3 Rear View of Ports

Specifications:

UP-I3GIG-H81N (I3)

- **MOTHERBOARD:** Gigabyte H81N
- **CPU:** Intel Core I3 4130 2.9Ghz
- **MEMORY:** 4 GB DDR3-1333 (Max 8GB only Win 7 64 bit)
- **HARD DRIVE:** 500GB SATA 5400 rpm
- **VIDEO GRAPHICS:** Intel HD Graphics VGA/DVI/HDM
- **Audio:** Realtek ALC887 High Definition
- **PORTS:** 4x USB 2.0, 2x USB 3.0, 1x RS232, 1x VGA, 1x HDMI, 1x DVI Audio Ports
- **LAN:** 1x RJ45 10/100/1000
- **CASING:** Modular Rugged Metal Housing Powder Coated
- **WEIGHT:** 3.3 lbs/1.5kg
- **POWER:** External 220W Power Supply Adaptor 10a
- **DIMENSIONS (LxWxH):** 58.5mm x 259.5mm x 186mm
- **CERTIFICATIONS:** FCC Class A, CE, RoHs
- **OPERATING SYSTEMS:** Optional

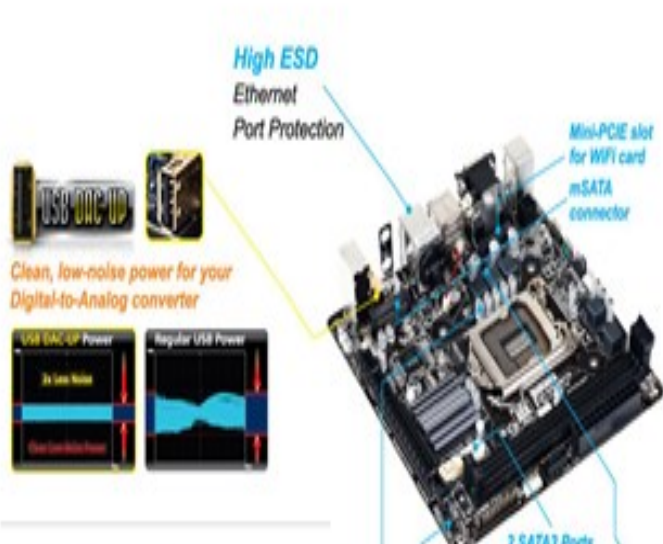

Option:

-  ini Box  t Part#U  IOUNT

POS Servers PC's

The UnyPOS POS Servers are Specially Designed for Hospitality and Industrial Environments installed with Premium Components for Speed and Reliability.



UP-3000 Full Size Case

Specification (I3)

Part# UP-3000A-I3-4G

- Intel I3 4160 3.6GHz CPU
- 4Gb DDR 1600/1333 Kingston Memory
- 500GB SATA 7200 rpm 16mm HDD
- Asus H81-MC Socket 1150 M-ATX Motherboard
- 1GB Onboard NIC
- 1x PCIe 2.0x16, 2x PCIe 2.0x1, 1x PCI, 1x SVGA, 1x LPT
- 1x DVI, 2X USB 3.0, 8x USB 2.0 (4 front & 4 back), 3x Audio
- 300W Power Supply 80+ Energy Star, INWIN MT Case (BK623)
- HD Shared Video NIC
- 24X DVD Burner
- HD Shared Video NIC

Specification (I5)

Part# UP-3000A-I5-8G

- Intel I5 4460 3.2 GHz CPU
- 8Gb DDR3 1600/1333 Kingston Memory
- All other specs same as above I3 model.

Specification (I7)

Part# UP-3000A-8GB

- Intel I7 4770 3.3GHz CPU
- 8Gb DDR3 1600/1333 Kingston Memory
- 500GB SATA 7200 rpm 16mm HDD
- Asus H81-MC Socket 1150 M-ATX Motherboard
- 1GB Onboard NIC
- 1x PCIe 2.0x16, 2x PCIe 2.0x1, 1x PCI, 1x SVGA, 1x LPT
- 1x DVI, 2X USB 3.0, 8x USB 2.0 (4 front & 4 back), 3x Audio
- 300W Power Supply 80+ Energy Star, Master CM Force 500 MT Case
- 500W Power Supply Cooler Master CM Force MT Case
- 24X DVD Burner
- HD Shared Video NIC



UP-2700 Mid Size Case



Part UP-2700A-Duo2.7-Mini

- Intel G3220 P4 3.0Ghz Dual Core 3M CPU
- 4Gb DDR3 1600/1333Memory
- 500GB SATA 7200rpm HDD
- Asus H81-MC Socket 1150 M-ATX Motherboard
- 1GB Onboard NIC
- 1x PCIe 2.0x16, 2x PCIe 2.0x1, 1X PCI, 1x SVGA, 1x DVI
- 1xSerial, 1x-Lpt1, 2xUSB 3.0, 8x USB 2.0, 3x Audio
- 300W Power Supply Mini Slim Case
- HD Shared Video

Option:

Mid-Tower Case Part# UP-2700A-Duo2.7-Mid

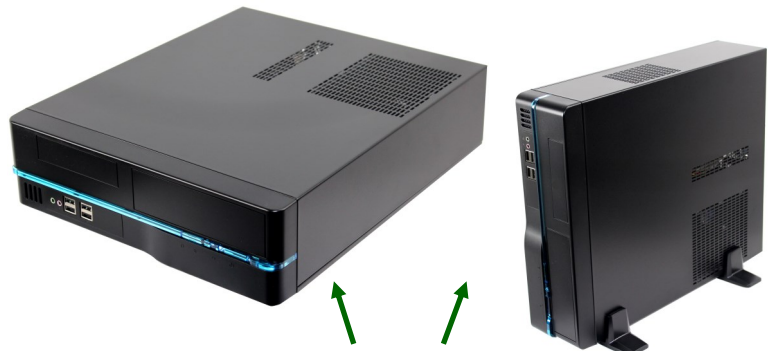

UP-2700 Slim Size Case

Rear Displays and Thermal POS Printer



8.4" TAP Mini Rear USB LCD Display

Part UNY-E08U (Bracket sold Separately)

- USB Driven
 - Includes Driver and USB Cable
- Recommended for Rear Display Advertising
Picture shown with rear display mounted to TAP-1500CD Terminal



10.4" TAP Mini Rear VGA LCD Display

Part UR-104-VGA-RD (Bracket Included)

- VGA Driven
 - Includes Driver
 - Includes Mounting Bracket
- Recommended for Rear Display Advertising



VFD 2x20 Line Display

Part UNY-VFD220U (USB)

Part UNY-VFD220S (Serial)

- VFD 2x20
 - Includes Driver
 - Includes Mounting Bracket
 - **Optional Magnetic Base Available**
- Recommended for Rear Display Advertising



Triple Interface

Thermal Printer

UNY-P13USLT

- **Resolution:** 203DPI
- **Interface:** Serial + USB + Ethernet
- **Print Width:** 64/80mm
- **Memory:** Ram-128Kb, NV Flash-256Kb
- **Print Speed:** 300mm/s
- **Paper Diameter:** 83mm
- **Line Space:** 3.75mm (adjustable)
- **Drivers:** Win98/NT/2000/XP/Win7

Sensors

- Print Head overheating protection
- Print head position
- Paper near end and Paper Out
- **Auto Cutter:** 150km

Main Features

- **Triple Interface** (USB-Serial-RJ45)
- Slim
- Fast
- Reliable
- Economical

Mounts and Accessories



Bar Code Hand-Held Scanner

Part# **UF-KS-380ARB-USB-B**

- Scan speed: 100 or 33 scans per second
- Wave Length : 670mm

Wall Mount Bracket (Heavy Duty)

Part# **UR-RTW03**

- Vesa Standard 75mm-100mm
- Loading capacity 3kg –20kg
- Up and down Adjust Pivot
- Left and Right Adjust Pivot

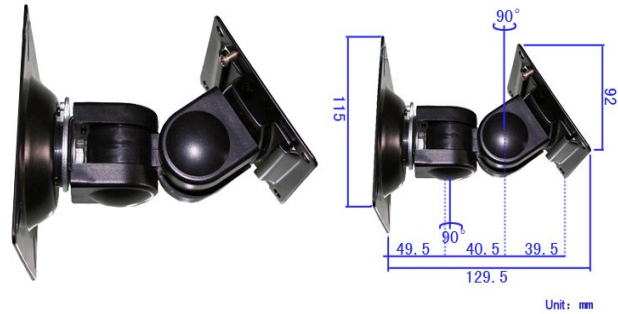

Adjustable Pole Mount

Part# **SP-001 (Black)**

- 360 Degree Rotate
- Adjustable length 510mm-765mm
- Vesa Standard 75mm-100mm
- Supports up to 25kg

Dual Mount Stand

Part# **U11-ADUOB (Black)**

- Vesa Standard 75mm-100mm
- Mounting Screws/Cable Included
- Cable Management



Universal Tablet 7-10" Holder

Part# **UP-031-TABHLD**

- Max Weight 3.3lbs
- Rotate 360 Pivot Degrees
- Mountable Bottom Plate
- Fits most 7"- 10" Tablets
- Lock Function Quick Release

LED Writing Boards

Help increase the sales of your company and your customer by offering the UnyPOS LED Writing boards. Instead of a traditional chalk board or poster the UnyPOS LED Writing Boards make advertisement more alive and effective in an eye catching way. Using the latest LED Technology our scratch resistant writing boards light up your message bright and clear that creates an visual effect and positive ROI (Return on Investment).



Model # **Size (cm)** **Size (inch)**

- UNY-WLED4030 40 x 30cm 12 x 18"
- UNY-WLED4060 40 x 60cm 18 x 24"
- UNY-WLED7050 70 x 50cm 20 x 28"
- UNY-WLED8060 80 x 60cm 24 x 32"

Options:

- UNY-WLED8-PKCR 8 Pack Color Markers
- UNY-WLED-TPOD Tripod Stand
- UNY-WELD-Con Converter 24

Ships standard with

- Chain and Hanging Hooks
- 8 Pack Markers and Cloth
- Remote Controller 24 Settings
- 12V Power Adaptor



Key Features

- Aluminum Alloy Frame
- Anti-Scratch Panel
- Tempered Glass Refined
- 52 Flash Modes
- USB Controller
- High Bright Philip LED 50/50 Light Source
- Life Span 100,000 hrs
- Portable



8 Pack Color Fluorescent 6mm Nib Marker Pen Set



Tripod Included for Larger Sizes above 12" x 18"

Panel and Rear Mount Terminals

The Panel PC Modular Terminal designed to support many Industrial and Gaming Industries. Components installed are similar to the ModsPOS Platform.

Specifications

PAN-P220UR-FAN (Fanless) 22"

- **TOUCH:** 5 Wire Resistive Anti-Glare
- **MOTHERBOARD:** Intel Motherboard D2550
- **CPU:** Intel Atom Dual Core 1.8Ghz CPU Fanless
- **MEMORY:** 4 GB DDR3-1333 Max 4GB
- **HARD DRIVE:** 250GB SATA 5400 rpm
- **VIDEO GRAPHICS:** Intel X4500
- **BRIGHTNESS:** 300 Nits
- **Contrast:** 1000:1
- **PORTS:** 4x USB 2.0, 1x RS232, 1x SVGA, 1x S-Video, 1x LPT1, 3x Audio
- **LAN:** 1x RJ45 10/100
- **CASING:** **Modular** Rugged Metal Housing
- **WEIGHT:** 28 lbs Gw Includes Packaging
- **POWER:** External Ac 12V, universal auto sensing, 36W
- **LCD DISPLAY:** TAP High Bright 22" 1680x1050 16.7M Colors
- **DIMENSIONS (LxWxH)** 22"x7"x17"
- **CERTIFICATIONS:** FCC Class A, CE, RoHS
- **OPERATING SYSTEMS:** Win 7 Pro 32 Bit

PAN-P220UR-I3 (I3) 22"

- **MOTHERBOARD:** Gigabyte H81N
- **CPU:** Intel I3-4130 Quad Core 2.9Ghz
- **MEMORY:** 4 GB DDR3-1333 Max 8GB
- **HARD DRIVE:** 250GB SATA 5400 rpm
- **VIDEO GRAPHICS:** Intel HD Graphics , VGA/DVI/HDMI
- **PORTS:** 4x USB 2.0, 2xUSB 3.0, 1x RS232, 1x SVGA, 1xDVI, 1x S-Video, 1x LPT1, 3x Audio
- **LAN:** 1x RJ45 10/100

PAN-P170UR-I3 (I3) 17"

PC Specs same as model Pan-P220UR-I3 above

- **LCD DISPLAY:** TAP High Bright 17" 11280x1024 16.7M Colors
- **DIMENSIONS (LxWxH)** 16"x7"x14"
- **WEIGHT:** 22 lbs Gw Includes Packaging



Rear Port View



Wall Mount Option

Industrial Grade Rear Mount Displays

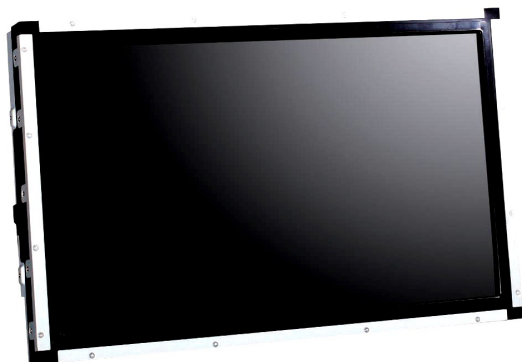

Drop in Replacement for ELO Model 1537L

TAP-C15-2RT (Dual USB/SER Resistive)

- **Touch:** 5 Wire Resistive Anti-Glare (Optional SAW Available)
- **Interface:** USB A-B and RS232
- **Resolution:** 1024(H) x 768(V)
- **Brightness:** 250 Nits , Contrast : 450:1
- **Signal Input:** Video/Analog Signal, Signal Sync TTL
- **OSD:** Control Brightness, contrast, auto, color, user color etc
- **Power Supply:** 12V DC 1.5A
- **Dimension (WxHxD)** 336mm x264mm x42.8mm
- **Color:** Grey

Options:

Upgrade to 17" TAP-C17-2RT

Free Standing Kiosk

The UnyPOS UNYMG301/UNYMG311 and UNYK0RDC are **Reliable, Attractive Free Standing Kiosks** that enhances your brand and are designed to accomplish a wide array of self-service and digital signage tasks in a

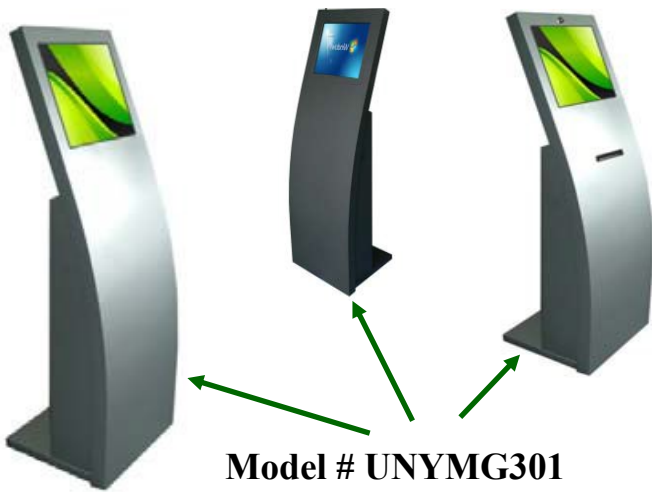

Model # UNYMG301



Model # UNYMG311



Model # UNYK0RDC

Model# UNYMG301/UNYMG311/UNYK0RDC

- **TOUCH:** 5 Surface Accoustic Anti-Glare
- **MOTHERBOARD:** Intel Motherboard MSI G41 Express Chipset
- **CPU:** Intel Dual Core G520
- **MEMORY:** 2 GB DDR1 Max 4GB
- **HARD DRIVE:** 320GB SATA 7200 rpm
- **LCD DISPLAY:** TAP 19"High Bright Display
- **VIDEO GRAPHICS:** Intel GMA x 950
- **BRIGHTNESS:** 300 Nits
- **Contrast:** 500:1
- **BRIGHTNESS:** 300 Nits
- **PORTS:** 4x USB 2.0, 1x RS232, 1x SVGA, 1x S-Video, 1x Lpt1
- **Audio:** 3 Ports (input/output/mic)
- **Multimedia:** Integrated Amplified HI-FI Speakers
- **LAN:** 1x RJ45 10/100
- **CASING:** **Modular** Rugged Quality Steel Metal Housing
- **POWER:** External 110/240vW Power Supply
- **OPERATING SYSTEMS:** Optional
-
- **Weight:** 48Kgs
- **Size (h x w x d):** 1385 x450 x 505 mm (**UNYMG301**)
- **Size (h x w x d):** 1620 x510x 470 mm (**UNYMG311**)
- **Size (h x w x d):** 1385 x450 x 505 mm (**UNYK0RDC**)
- **Packing:** Packed in non-fumigation Wooden Crate/Carton
- **Packing Dimension:** 1550 x 575 x 575mm (**UNYMG301**)
- **Packing Dimension:** 1750 x 575 x 575mm (**UNYMG311**)
- **Packing Dimension:** 1550 x 575 x 575mm (**UNYK0RDC**)

Options:

- **PC Camera:** USB 2.0 High Quality PC Camera
- **Thermal Printer:** Epson T532 80mm w/auto-cut
- **Barcode Scanner:** Metrologic MS3480
- **Metal Keyboard:** 66 Stainless Steel Keyboard with Trackball
- **RF Card Reader :** ISO 1443-A standard. RS-232 interface
- **Card Reader:** KDE KT-2250 Swipe Reader
- **Color:** Various Color (standard black)
- **UPS:** Upon Request

Key Features

- **Free Standing Design**
- **High Brightness LCD**
- **High Resolution SAW Touch**
- **High Quality Metallic Paint**
- **Sturdy**
- **Reliable**

Information Kiosk is designed for self-service information. It can be used at various environments and industries ranging from communications to retail, transportation, medical and much more.



**For more Information please
contact us at 1-877-219-3988 or
visit**

www.UnyPOS.com

Email: sales@unypos.com

Providing Results!